

Jamesway Incubation Systems

2-Column Incubator Rack

Assembly Instructions and Parts

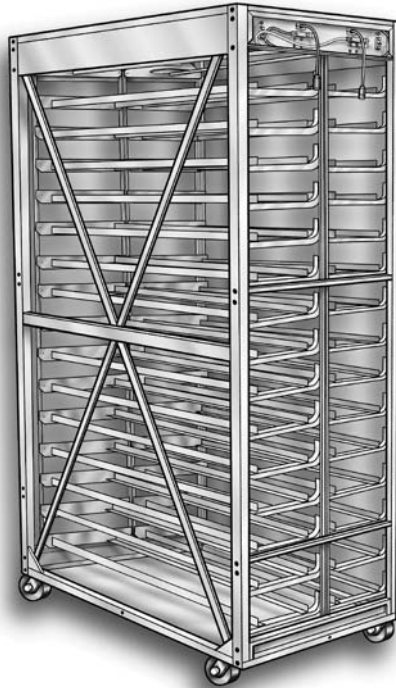

MANRAKAC12
Revision E

Jamesway Incubator Company Inc.
30 High Ridge Court
Cambridge, Ont., Canada
N1R 7L3

tel: (519) 624-4646
fax: (519) 624-5803
email for customer service:
service@jamesway.com



*This book and its contents are the property of the Jamesway Incubator Company Inc.
Reproduction in whole or in part, by any means, without permission
of Jamesway Incubator Company Inc. is prohibited.
© 2000 Jamesway Incubator Company Inc.*

2-COLUMN INCUBATOR RACK

Table of Contents

Important Assembly Notes	5
Assembly of Outer Frame	5
Installation of Casters	8
Installation of Turner Shaft	9
Installation of Hanging Bars	10
Installation of Egg Tray Frames	11
Installation of Rail Spacers	13
Squaring and Tightening the Rack	13
Installation of Tray Spacers	16
Installation of the Drive Bar	17
Installation of Air Cylinder and Tubing	18
Installation of Turn Sensor	19
Installation of Nylon Bumpers	20
Final Inspection	21
Application of Locktite	21
Accessories	22
Index	23
Inspection Procedure	25



ANTI-SEIZE - Use Anti-seize compound (PB4665) where indicated by this symbol.



LOCKTITE - Use Locktite (P2885) where indicated by this symbol.

IMPORTANT ASSEMBLY NOTES

A Jamesway Technician must supervise the assembly of all incubator racks. The assembly check lists, supplied with the instructions in each incubator rack package, must be used for each rack. Careful, methodical assembly of the incubator racks will prevent many problems with rack turning.

A properly assembled rack should turn smoothly and easily with an air pressure of 25 PSI.

Tighten all Allen Head cap screws using only the Allen key supplied in the hardware pack. Apply only hand leverage when tightening fasteners.

ASSEMBLY OF OUTER FRAME

Step 1: Attach the side frames (Item 1) to the top frame (Item 2) using the Allen Head cap screws (Item 4). Insert the bottom rail assembly (Item 3) and attach using Item 4.

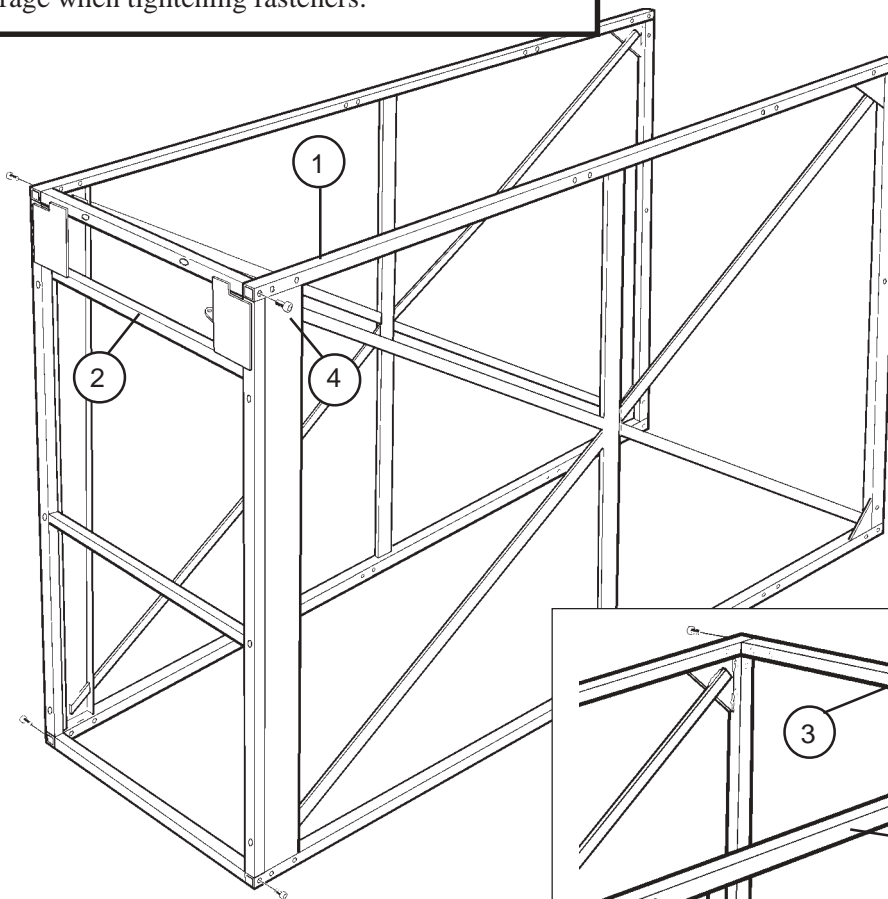

Figure 1: Attaching Side Frames

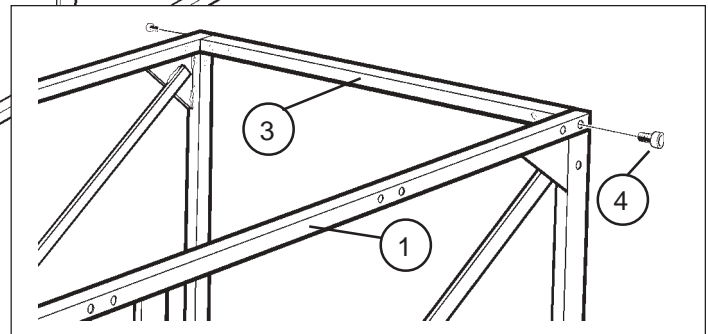

Figure 2: Attaching Bottom Frame

ITEM	PART NO.	DESCRIPTION
1	AB4101B	Side Frame Assembly, Chicken
	AB5849	Side Frame Assembly, Turkey
2	AB6424	Top Frame Assembly
3	AB6419	Bottom Rail Assembly
4	O880510	5/16"-18 x 5/8" Allen Head Cap Screw

Step 2: Insert the bottom panel (Item 1) with the smooth flat surface facing in and the angled edge up between the side frames. Secure using Items 5 and 6 (Figure 3). Ensure all screws are snug.

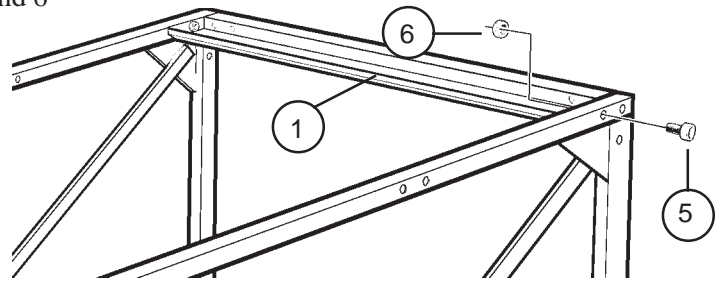

Figure 3: Inserting the Bottom Panel

Step 3: Insert the horizontal back rails (Item 2) between the side frames and secure using Item 5 (Figure 4).

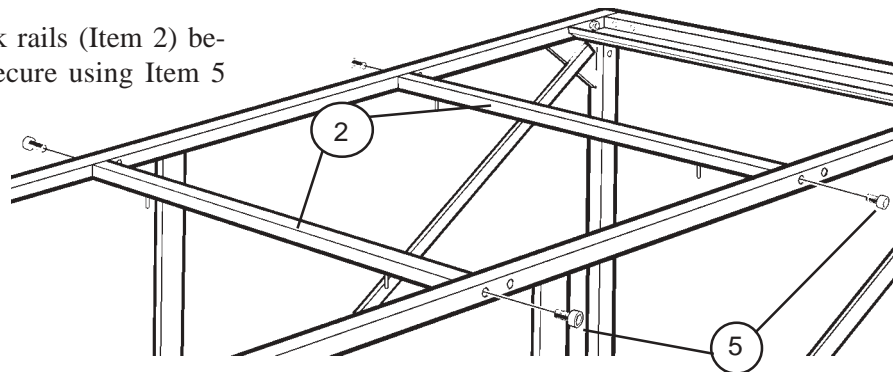

Figure 4: Inserting the Horizontal Back Rails

Step 4: Insert the bearing panel assembly (Item 3) flush with the top frame assembly. Face bearing blocks inward. Secure using Items 4, 5 and 6 (Figure 5).

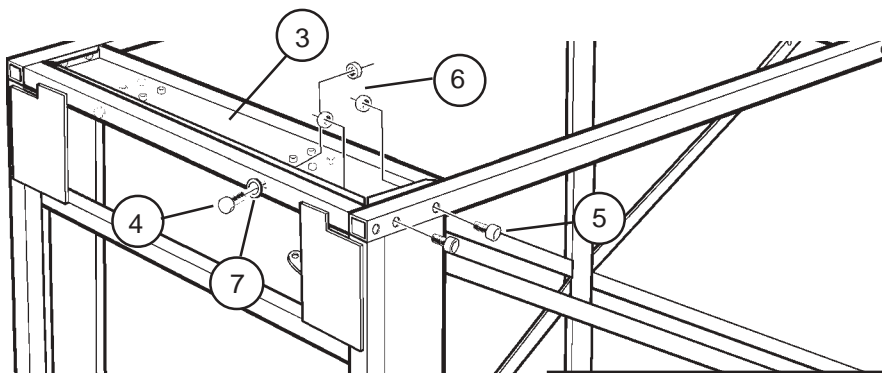

Figure 5: Inserting the Bearing Panel Assembly

ITEM	PART No.	DESCRIPTION
1	MB17271	Bottom Panel
2	AB6421	Horizontal Back Rail Assembly
3	AB6422	Bearing Panel Assembly
4	O240528	5/16" - 18 x 1 3/4" Hex Head Cap Screw
5	O880510	5/16"-18 x 5/8" Allen Head Cap Screw
6	O490500	5/16" - 18 Hex Lock Nut
7	O660500	5/16" Flat Washer

Step 5: Insert the bottom pan (Item 1) between the side frames of the rack. Be sure that the flanged edge is facing the top of the rack. Fasten the bottom pan to the side frames using Items 2 and 3 (Figure 6).

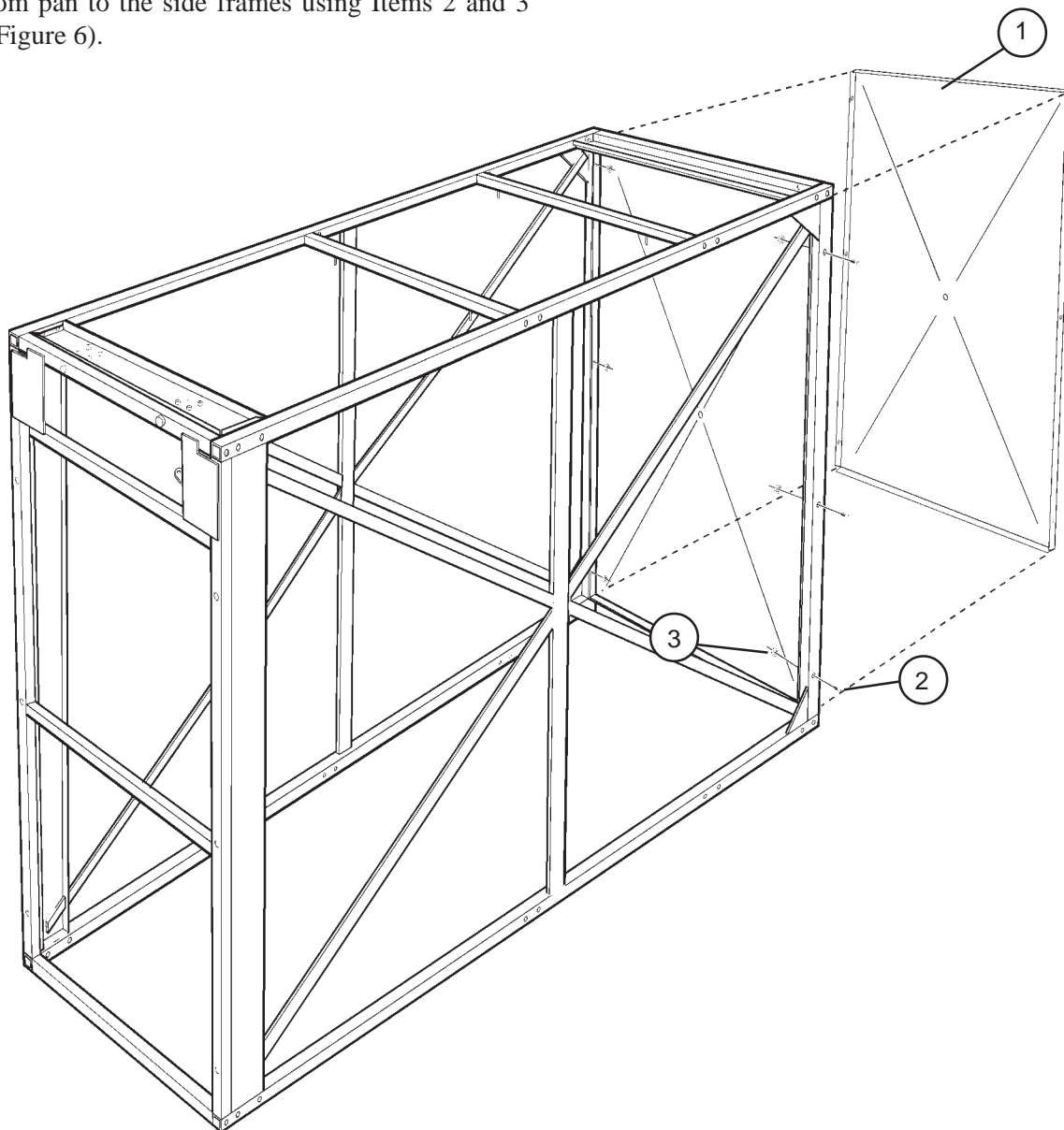

Figure 6: Inserting the Bottom Pan

ITEM	PART No.	DESCRIPTION
1	MB17272	Bottom Pan
2	O880510	5/16" - 18 x 5/8" Allen Head Cap Screw
3	O490500	5/16" - 18 Hex Lock Nut

INSTALLATION OF CASTERS

Step 6: At the top end, install two of the swivel casters (Item 1) using Items 2, 3 and 4.

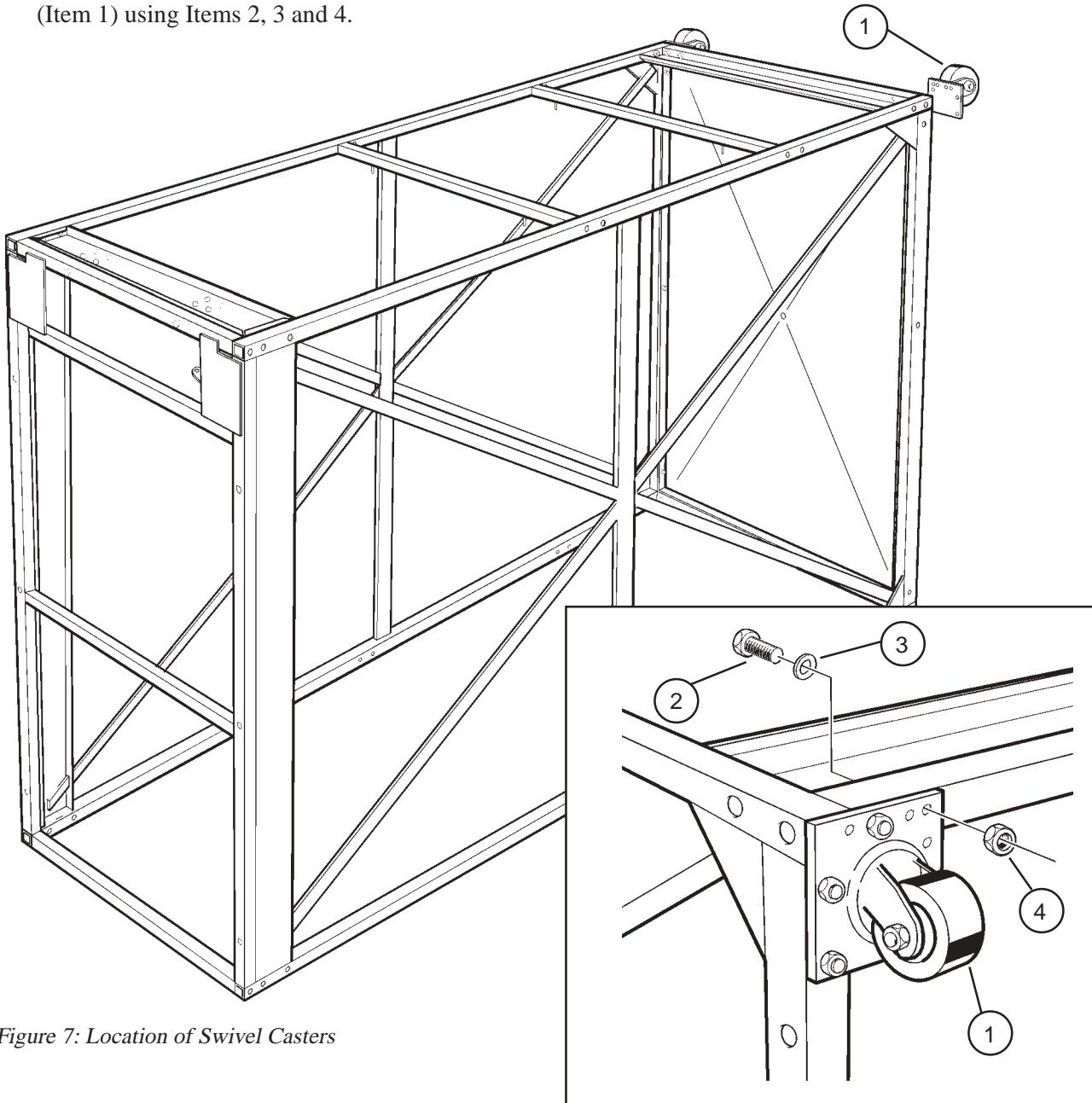

Figure 7: Location of Swivel Casters

Figure 8: Installing the Swivel Casters

ITEM	PART NO.	DESCRIPTION
1	PB4355A	Swivel Caster
2	O240528	5/16" - 18 x 1 3/4" Hex Head Cap Screw
3	O660500	5/16" Flat Washer
4	O490500	5/16" - 18 Hex Lock Nut

INSTALLATION OF TURNER SHAFT

Step 7: Flip the rack over so that the back of the rack is facing the floor. Install the second bottom panel (Item 1) using Items 6 and 9, and the two other swivel casters (Item 2) using Items 7, 8 and 9 (Figure 9).

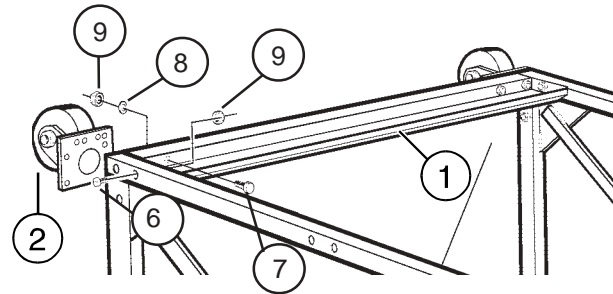

Figure 9: Installing the Bottom Panel

Step 8: Apply Anti-Seize compound to the inside of the bearing blocks (Item 4, Figure 10).

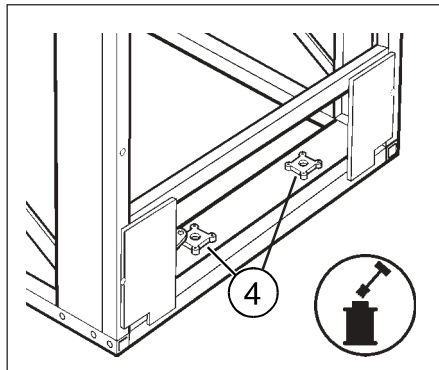

Figure 10: Applying Anti-Seize Compound

Step 9: Insert a turner shaft assembly (Item 3) into each bearing block (Item 4) of the bearing panel (Figure 10 & 11). Carefully place the front bearing panel (Item 5) over the two turner shafts and between the side frames (Figure 12). Secure loosely with Items 6, 7, 8 and 9.

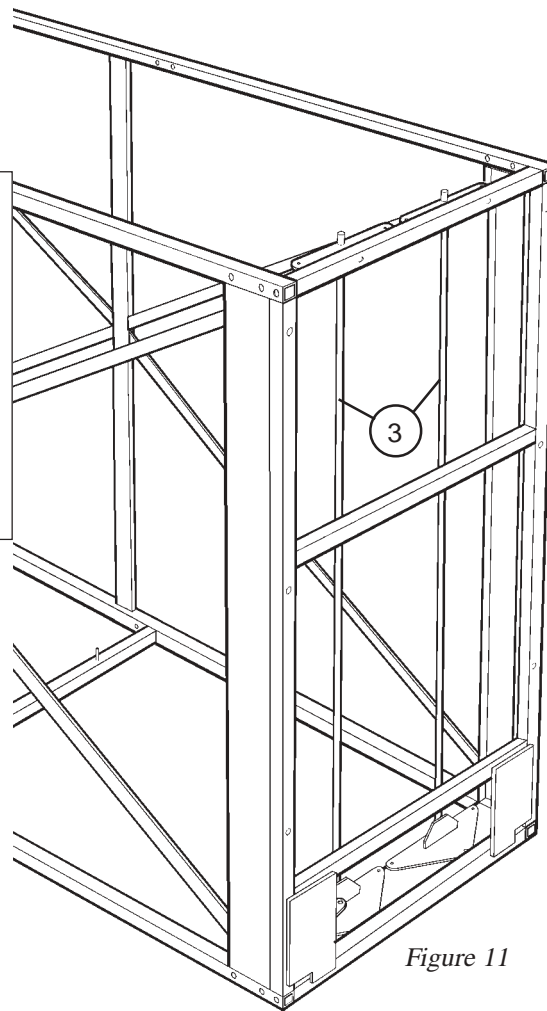

Figure 11

ITEM	PART No.	DESCRIPTION
1	MB17271	Bottom Panel
2	PB4355A	Swivel Caster
3	AB3553	Turner Shaft Assembly
4	PB4911	Bearing Block
5	AB6547	Front Bearing Panel Assembly
6	O880510	5/16" - 18 x 5/8" Allen Head Cap Screw
7	O240528	5/16" - 18 x 1 3/4" Hex Head Cap Screw
8	O660500	5/16" Flat Washer
9	O490500	5/16" - 18 Hex Lock Nut

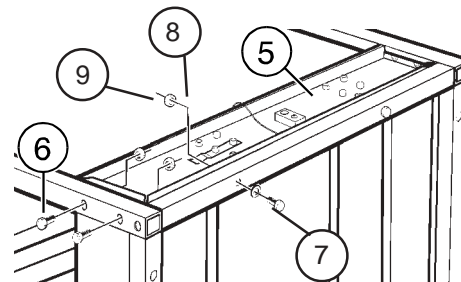

Figure 12: Placing the Front Bearing Panel

INSTALLATION OF HANGING BARS

(also known as turning bars)

Step 10: Place a wear strip (Item 1) over the pins on each of the back rails (Figure 13).

Step 11: Lay a hanging bar assembly (Item 2) onto the back side of the rack and carefully insert the top pin (the short pin) of the hanging bar through the hole in the turner shaft end piece. Repeat with 3 more hanging bars. Force a retaining ring (Item 3) over each short pin.

NOTE: Make sure it is the short pin that is inserted into the turning shaft end-piece.

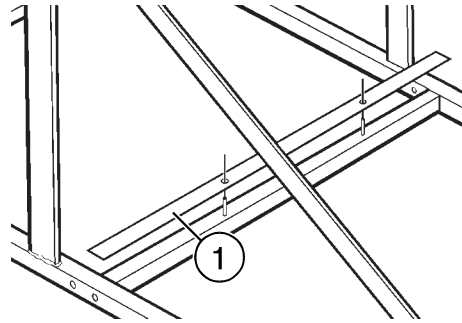

Figure 13: Placing Wear Strip

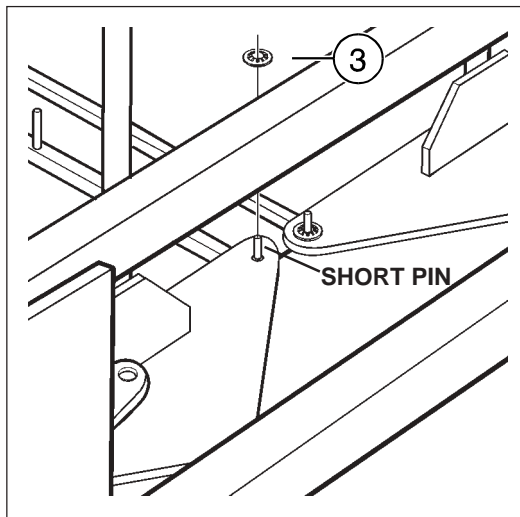

Figure 14: Placing Retaining Ring

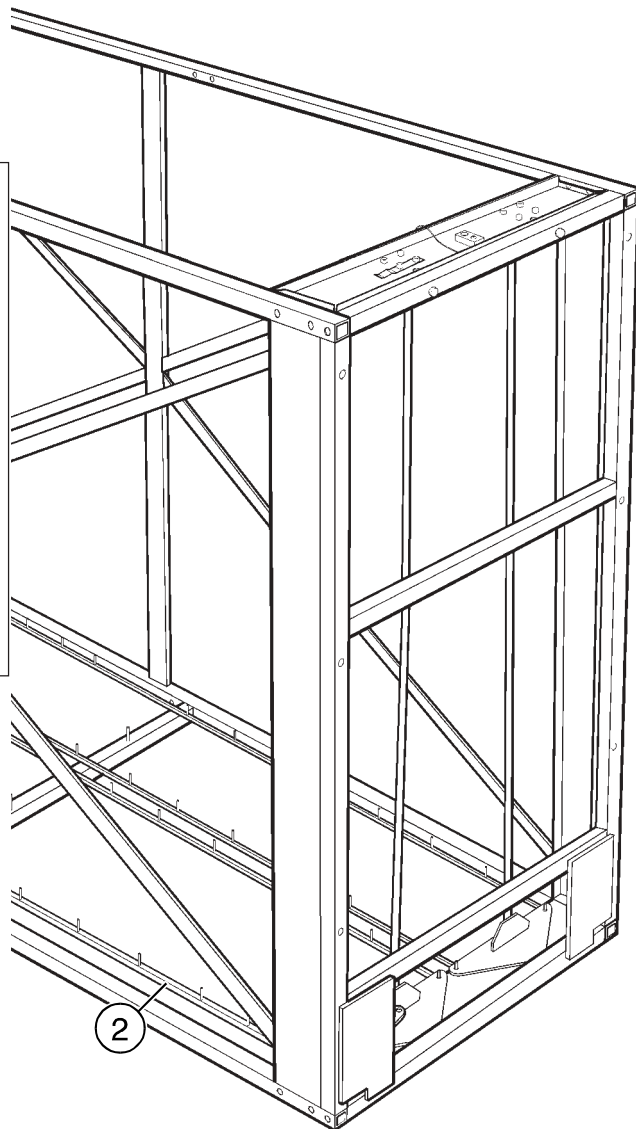

Figure 15: Hanging Bar Assembly

ITEM	PART NO.	DESCRIPTION
1	MB17280	Wear Strip
2	AB5696	Hanging Bar Assembly Chicken or,
	AB5848	Hanging Bar Assembly Turkey
3	PB3774	Retaining Ring

INSTALLATION OF EGG TRAY FRAMES

Note: When assembling the egg tray frames, **it is very important** to use the proper torque setting on your drill. The proper way to set up your drill is to use the low end power setting then turn the clutch setting until the screw bottoms out. Back up the setting by one (1) and check that the screw does not go all the way down. If the screw does go all the way down, adjust your setting up by one (1). This setting should allow the screw to go in without over tightening.

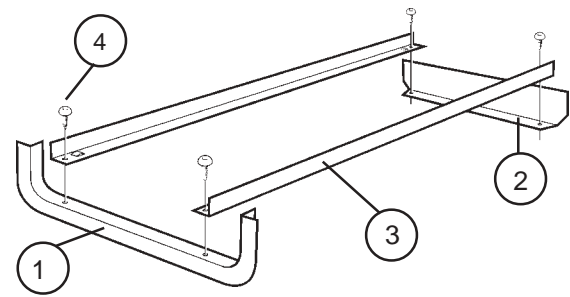

Figure 16: Assembly of Egg Tray Frames

Step 12: Assemble each of the egg tray frames. For each frame, attach the front and rear frame rails by fastening the frame rails (Items 1, 2, 3) with Item 4 (Figure 16).

Note: there are 30 frames for a chicken rack, 26 frames for a turkey rack.

ITEM	PART No.	DESCRIPTION
1	MB16816	Front Frame Rail, Chicken
	MB16856	Front Frame Rail, Turkey
2	MB16705	Rear Frame Rail, Chicken
	MB16857	Rear Frame Rail, Turkey
3	MB17732	Frame Rail, Chicken
	MB17733	Frame Rail, Turkey
4	P6067	No. 8 x 3/8" Quadrex Screw

Step 13: Check each egg tray frame for squareness before installing them into the rack. This can be done by constructing and using an egg tray frame template as illustrated in Figure 17. The materials required can be taken from the crate that the egg trays come in. The template should allow for 1/32" on both sides of the rail for easy placement and removal of the egg tray frames. Failure to square egg trays when assembled, may lead to extreme interference and further correction as in Step 20.

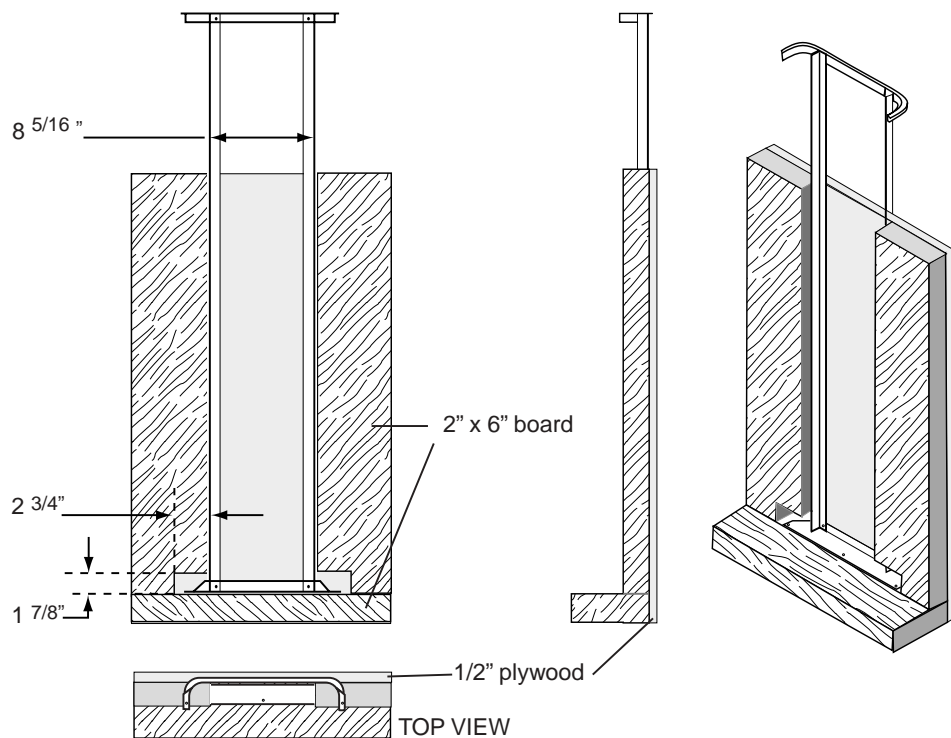

Figure 17: Egg Tray Frame Template

Step 14: Beginning at the bottom of the rack, place one egg tray frame assembly (Item 1) over each pair of pins on the hanging bars. Tilt all of the egg tray frames against the bottom front panel, towards the casters (Figure 18).

Step 16: Attach a retaining ring (Item 3) over each hanging bar pin that protrudes through the front end of each turner shaft (see Figure 20).

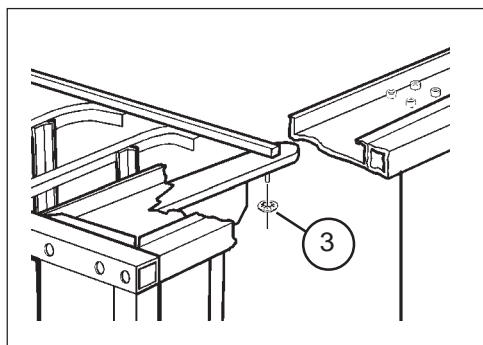

Figure 18: Placement of Egg Frame Assemblies

Figure 20: Attaching Retaining Rings

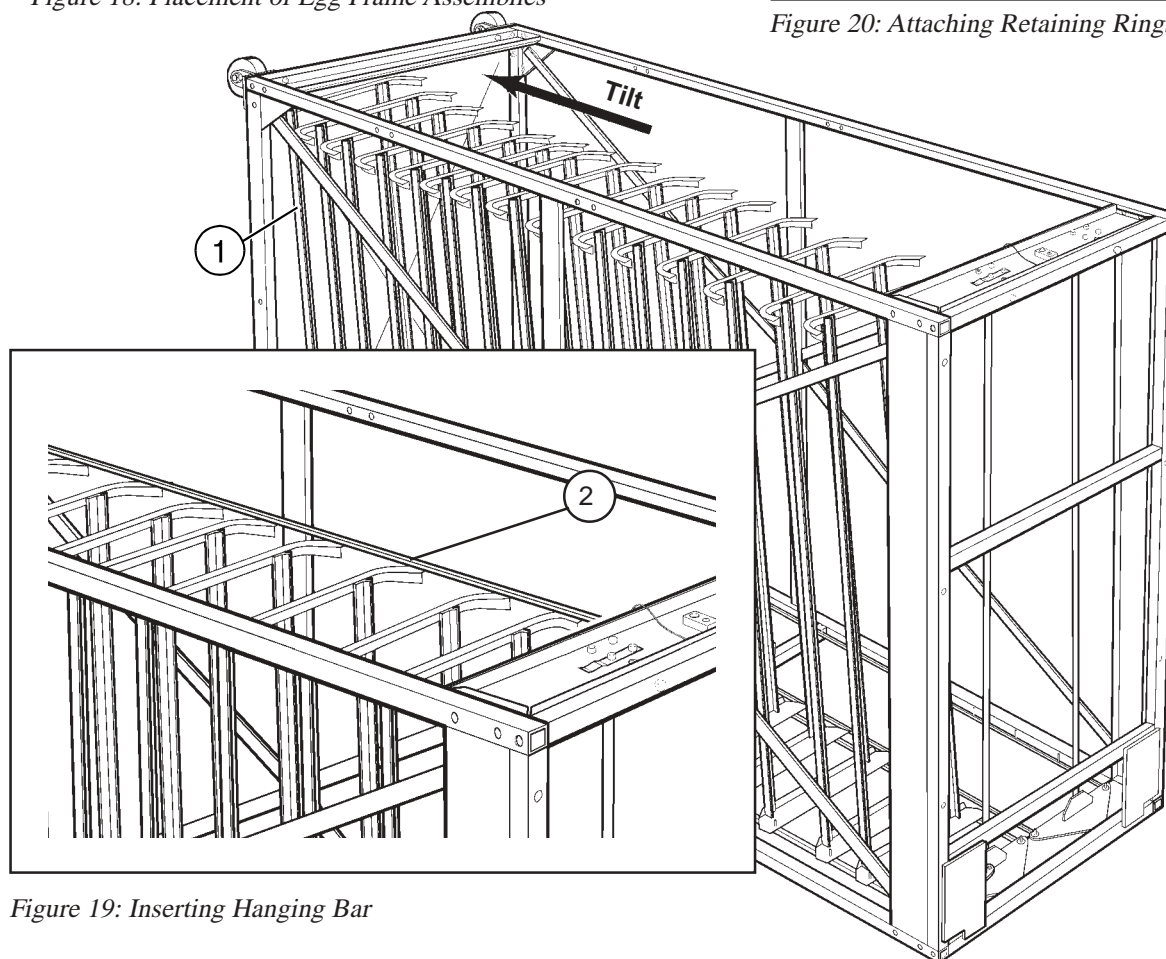

Figure 19: Inserting Hanging Bar

Step 15: Insert a hanging bar (Item 2) through the end of the turner shaft. Carefully insert the pins of the hanging bar through the holes in the front egg tray frame rails (see Figure 19). Slide the outside hanging bars under the side frame end rail. Install the remaining three hanging bars.

ITEM	PART No.	DESCRIPTION
1	AB6096	Egg Tray Frame Assembly, Chicken
	AB6144	Egg Tray Frame Assembly, Turkey
2	AB5696	Hanging Bar Assembly Chicken or,
	AB5848	Hanging Bar Assembly, Turkey
3	PB3774	Retaining Ring

INSTALLATION OF RAIL SPACERS

Step 17: Insert the Front Rail Spacers (Item 1) and fasten loosely with (Item 2).

Note: The screws securing the front spacer rail clips must face downwards towards the casters.

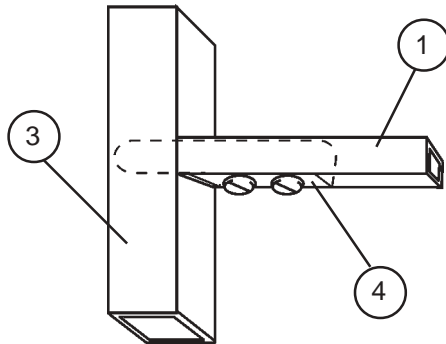

Figure 21: Position of Spacer Rail Clip on the Front Rail Spacer Bar

Step 18: Stand the rack up on its casters.

SQUARING AND TIGHTENING THE RACK

Note: As the rack is squared and all fasteners tightened, apply only hand leverage using the Allen keys supplied in each hardware package.

Step 19: Tighten the side frames to the top frame in all four corners as in Figure 23.

Step 20: On one side only, tighten down the bolts that attach that particular side frame to its castors as in Figure 24.

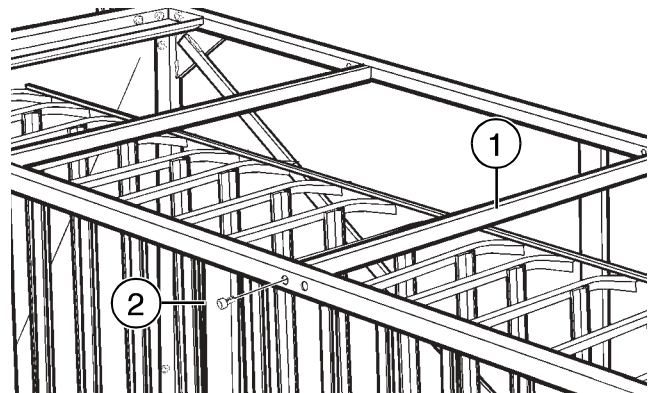

Figure 22: Installing Rail Spacers

ITEM	PART No.	DESCRIPTION
1	AB6420	Front Rail Spacer Bar Assembly
2	O880510	5/16-18 x 5/8" Allen Head Cap Screw
3	AB4101B	Side Frame Assembly, Chicken or AB5849
4	MB16021	Spacer Rail Clip

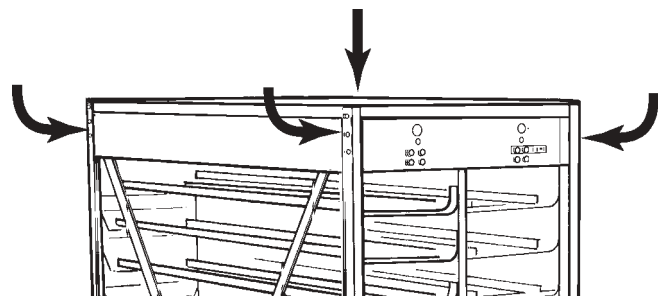

Figure 23: Tightening the Top Frame to the Side Frames

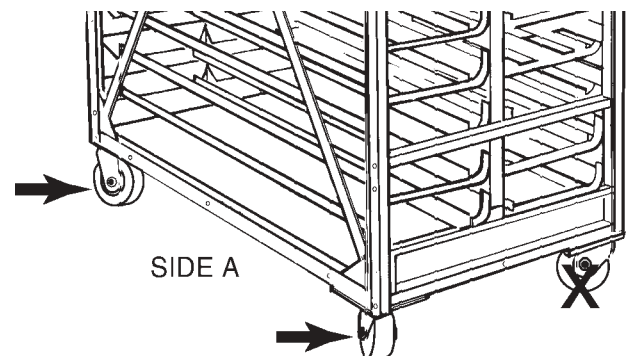

Figure 24: Tightening one Side Frame to its Castors

Step 21: Check for squareness using either the front or the back of the incubator rack as in Figure 25.

Step 22: On the opposing side of the castors that were tightened; adjust the frame left or right until the incubator rack is squared as in Figure 26.

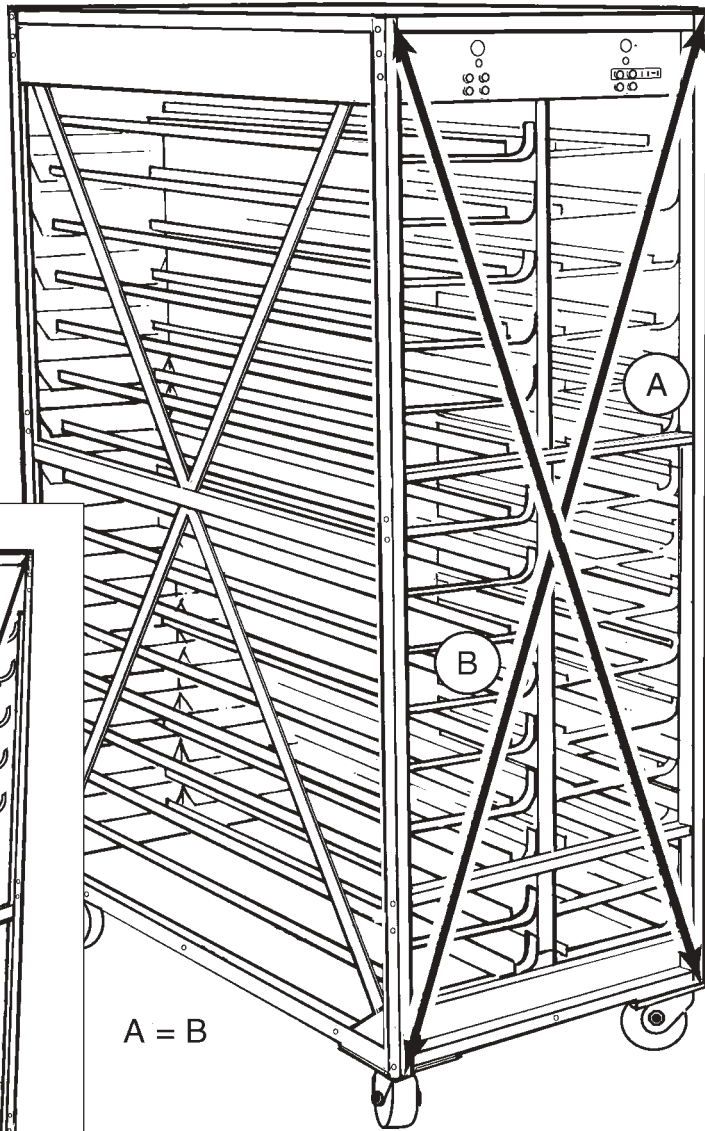

Figure 25: Checking for Squareness from the Front of the Rack

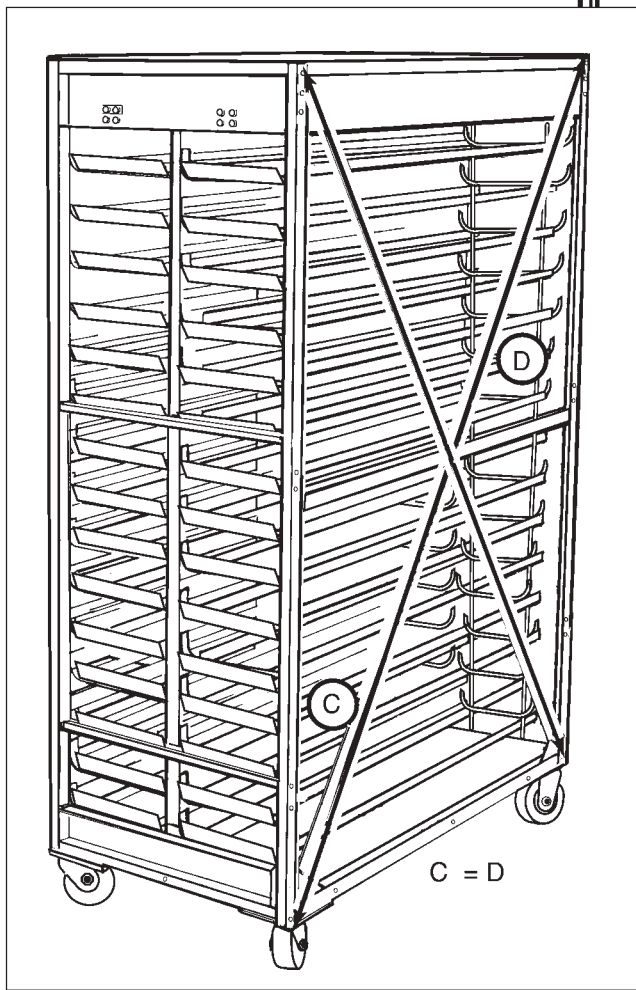

Figure 26: Adjusting Frame Opposing Side

Step 23: Tighten the casters on the opposing side first, as in Figure 27, then tighten the bolts of the first two casters.

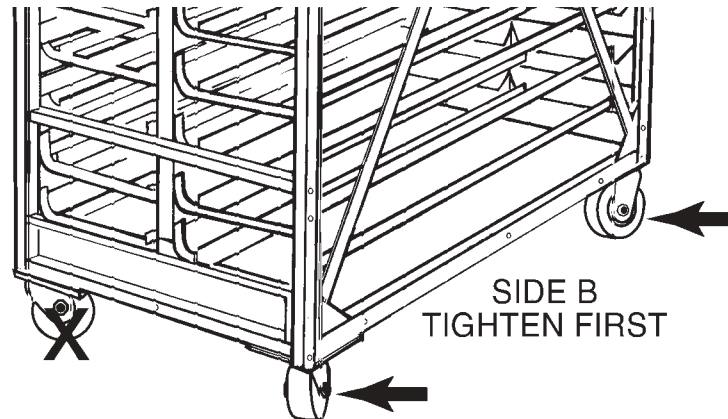

Figure 27: Tightening the Casters on the Opposing Side

Step 24: Tighten the rest of the bolts on the incubator rack using only hand leverage and the Allen keys provided.

Step 26: Your Jamesway Technician will inspect the rack for the free movement of egg tray frames.

Each column of egg tray frames should be checked for smooth, easy turning. Correct all drag points, points of wear, and interference between moving and stationary parts.

If the individual egg tray frames are not squared properly when assembled, severe drag points can occur at diagonally opposite corners: “A” and “B” (see Figure 28). This causes extreme interference when multiplied by 26 or 30 egg tray frames. This condition can generally be corrected, even at this stage of assembly, by manipulating the egg tray frame from the front of the rack.

FRONT OF THE RACK

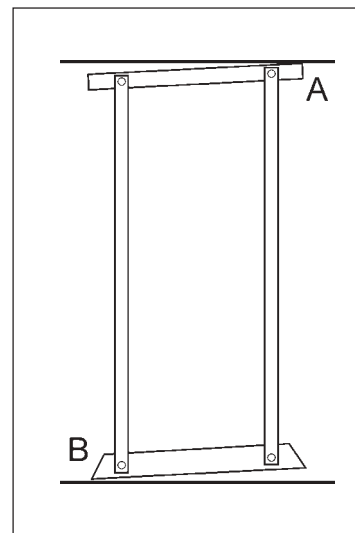

Figure 28: Severe Drag Points on Corners A and B

INSTALLATION OF TRAY SPACERS

Step 27: When all points of interference are corrected, install two tray spacers (Item 2) using drive rivets (Item 1) as in Figure 29. Water pump pliers (Channel-lock pliers) work well for this purpose (Figure 30). Apply a small amount of anti-seize compound between Items 1, 2 and 3. Install the tray spacers so that they point in the same direction.

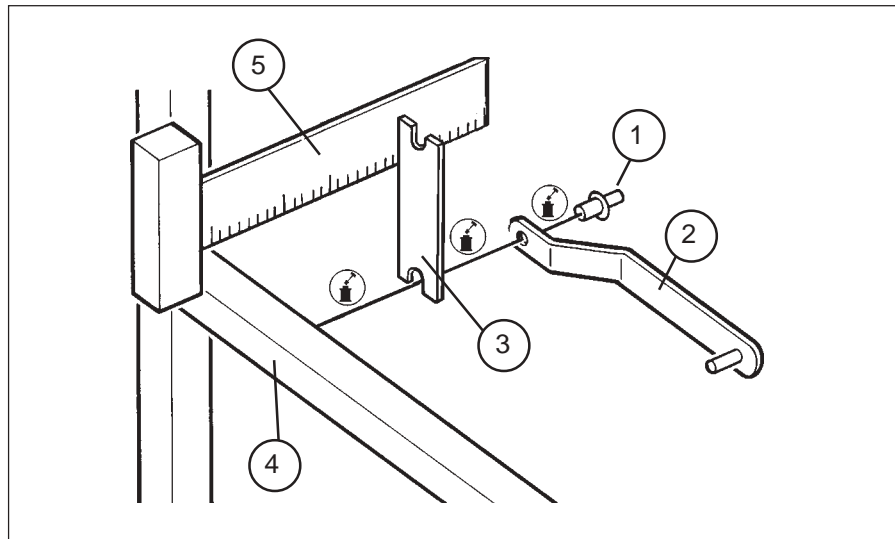

Figure 29: Installing Tray Spacers

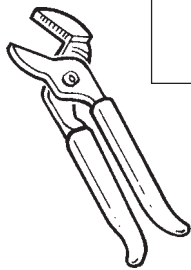

Figure 30: Water Pump or Channel-lock Pliers

ITEM	PART No.	DESCRIPTION
1	P6060	Rivet 1/4" x 3/16" Pin Grip Drive
2	AB3556	Tray Spacer Assembly
3	MB17260	Tray Spacer Clearance Gauge
4	AB6420	Front Rail Spacer Bar Assembly
5		Square, not supplied

Step 28: Square the front rail spacers to the side frames (Figure 29). The front rail spacers must be square with the front of the side frames otherwise the tray spacers may pull out of the hanging bars during turning. Check the columns of egg tray frames for smooth easy turning. Correct all points of interference before connecting the drive bar.

INSTALLATION OF THE DRIVE BAR

Step 29: For this procedure, use a step ladder with the rack upright. **Do not use the rack frame as a ladder.** Install the drive bar assembly (Item 1) using Item 2, 3 and 4. Install the cylinder support (Item 5) using Items 6, 7 and 8. Keep the cylinder support at the outer end of the drive bar support pin to avoid interference with the drive bar (Figure 31).

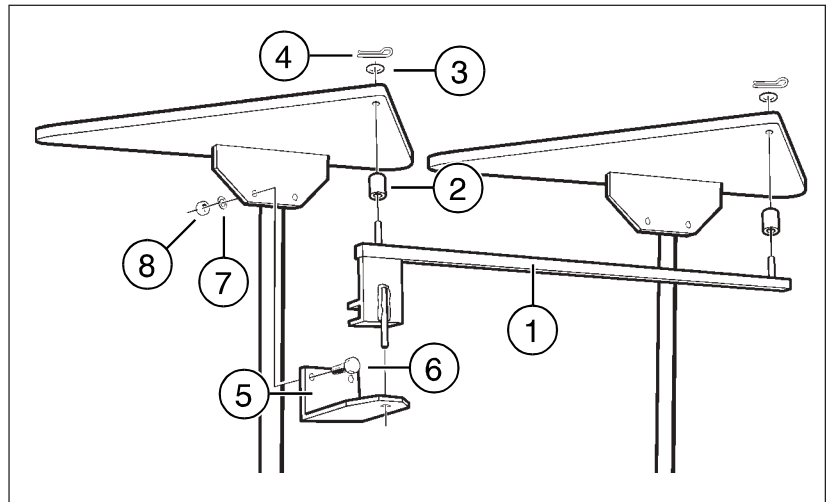

Figure 31: Drive Bar installation

Step 30: Check the turning of the columns of egg tray frames (Figure 32). All columns should turn easily and in unison. If they do not, correct all points of interference.

ITEM	PART No.	DESCRIPTION
1	AB6426	Drive Bar Assembly
2	PB12	Spacer Washer
3	P454	1/4" Sae Washer
4	P976	Cotter Pin 3/32" x 3/4"
5	MB16597	Cylinder Support Bracket
6	P336	1/4"- 20 x 3/4" Hex Head Bolt
7	P463	1/4" Lock Washer
8	P557	1/4"- 20 Hex Nut

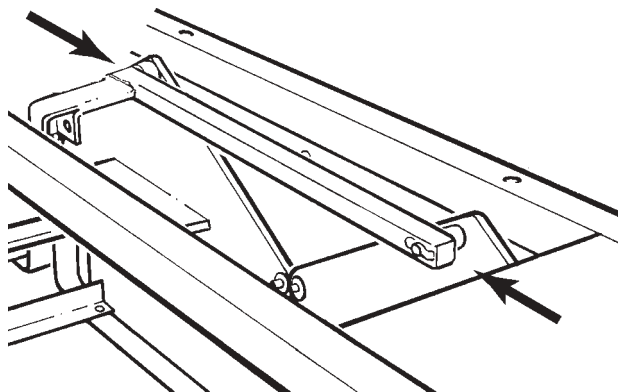

Figure 32: Proper Turning of Egg Tray Frames

INSTALLATION OF AIR CYLINDER AND TUBING

Step 31: Apply thread sealant or teflon tape to the threads of the elbow and orifice assembly (Item 2). Take care not to cover the hole in the orifice. Install Item 2 carefully into the air cylinder (see Figure 33).

Ensure that the elbow and orifice assemblies face in the same parallel plane as the top of the rack and are directed as shown (see Figure 34). Install the cylinder into the rack using Items 3, 4 and 5.

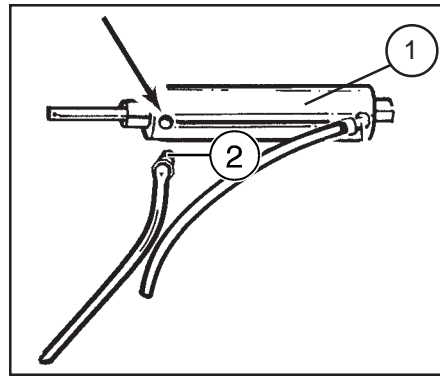

Figure 33 : Attaching the Elbow and Orifice Assembly

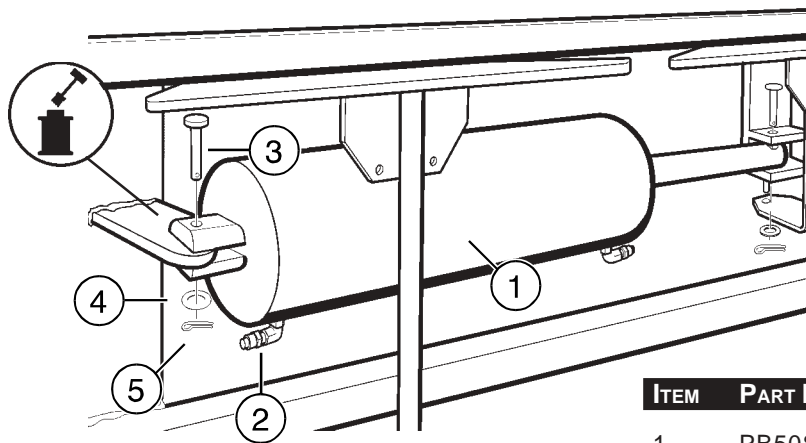

Figure 34: Installing the Air Cylinder

Step 32: Cut Item 6 (1/4" black tubing) from the quick connect end, leaving 56" (142 cm) from the cut to the elbow and orifice. Ensure that the cut is uniform. Cut Item 7 (1/4" clear tubing) from the quick connect end, leaving 50" (127 cm) from the cut to the elbow and orifice. Ensure that the cut is uniform. Run the 56" of black tubing and the 50" of clear tubing (Items 6 and 7) from the front bearing panel along the top of the rack to the air cylinder (Figure 35). Use Items 8 and 9 to ensure a snug fit and avoid interference.

Set aside the two (2) short, cut off pieces of Item 6 (1/4" black tubing) and Item 7 (1/4" clear tubing). They will be used when the racks are placed in the incubator to run the air in series from rack to rack.

ITEM	PART No.	DESCRIPTION
1	PB5086	Air Cylinder 1/2" Shaft
2	AB3559P	Elbow and Orifice Assembly
3	P2968	Clevis Pin 1/4" x 1 1/4"
4	P454	5/16" Sae Washer
5	P976	Cotter Pin 3/32" x 3/4"
6	P4254	84" - 1/4" Black Tubing
7	P4253	84" - 1/4" Clear Tubing
8	PB1798	1/4" Plastic Clip
9	P6082	#10-18 x 1/2" Self-drilling Screw

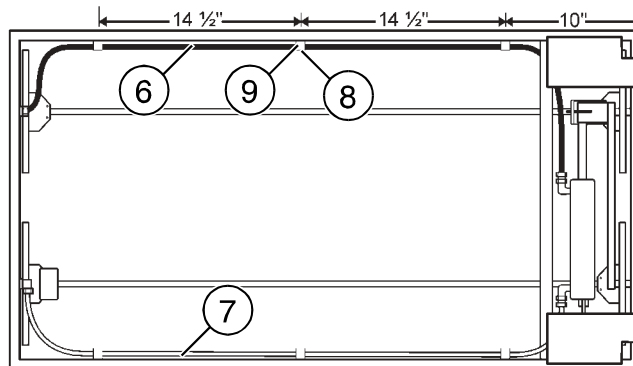

Figure 35: Installing the Tubing

INSTALLATION OF TURN SENSOR

Step 33: Install the turn switch box assembly (Item 1) onto the turner shaft assembly using Items 2, 3 and 4. Insert the cord assemblies (Items 5 and 6) through the holes in the front bearing panel. Secure the cables with Items 11, 12 and 13. The end of the molded plug of the cord assembly (Item 6) should extend 15" (38 cm.) beyond the strain relief bushing (Item 13). The end of Item 5 should extend 17" (43 cm.) beyond the strain relief bushing. Route the cord assemblies and air lines so they do not interfere with any moving part. See Figure 36.

ITEM	PART No.	DESCRIPTION
1	AB6537	Turn Switch Box Assembly
2	MB16292	Shim
3	P463	1/4" Lockwasher
4	P557	1/4"- 20 Hex Nut
5	AB6247	Cord Assembly, Female
6	AB6246	Cord Assembly, Male
7	AB3559P	90° Elbow
8	P3090	Brass Connector 1/4" x 1/8"
9	MB17191	Spacer
10	P3088	Brass Tee
	P3090	Brass Connector 1/4" x 1/8"
11	MB17090	Retainer
12	P6082	#10-18 x 1/2" Self-tapping Screw
13	P814	Strain Relief Bushing
14	PB4389	Foster Brass Plug
15	PB4390	Foster Brass Socket
16	P3248	Palnut
17	PB3294	Compression Nut with Ferrule
18	PB5075	Hitch Pin
19	PB5076	Pin Block

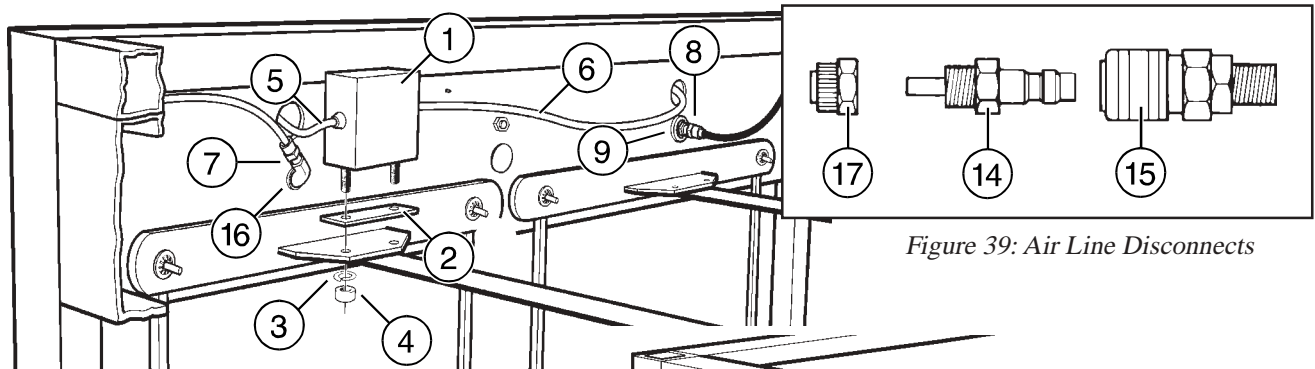

Figure 36: Installing the Turn Switch Box Assembly

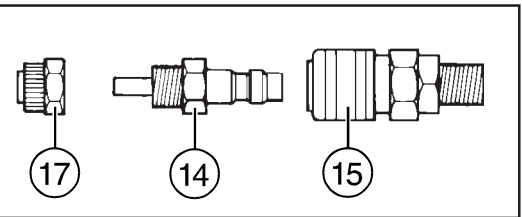

Figure 39: Air Line Disconnects

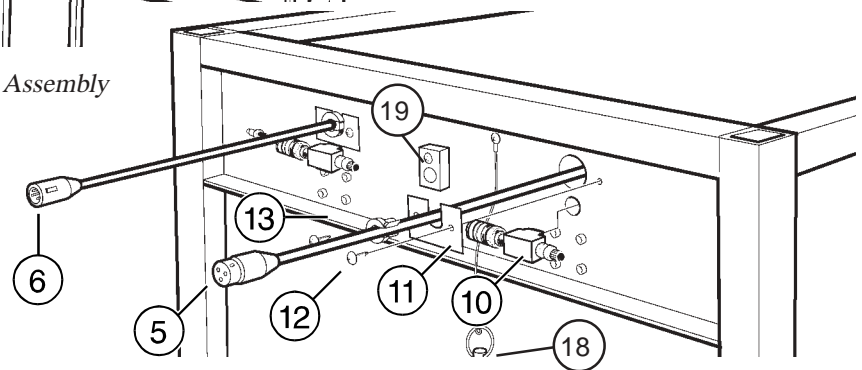

Figure 37: Installing the Cord Assemblies and Connectors

NOTE: The elbow and orifice (Item 7) for the clear tubing must be on an angle so that it does not interfere with the rotation of the turner shaft (Figure 38). Test by turning the shaft. If it interferes, readjust the elbow and orifice.

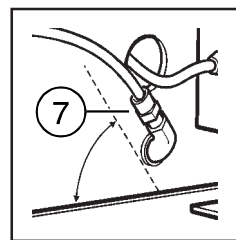

Figure 38: Tubing must clear turner Shaft

INSTALLATION OF NYLON BUMPERS

Step 34: Attach the four nylon bumpers (Item 1) to the base of the completed rack assembly as illustrated below using self drilling tapping screws (Item 2).

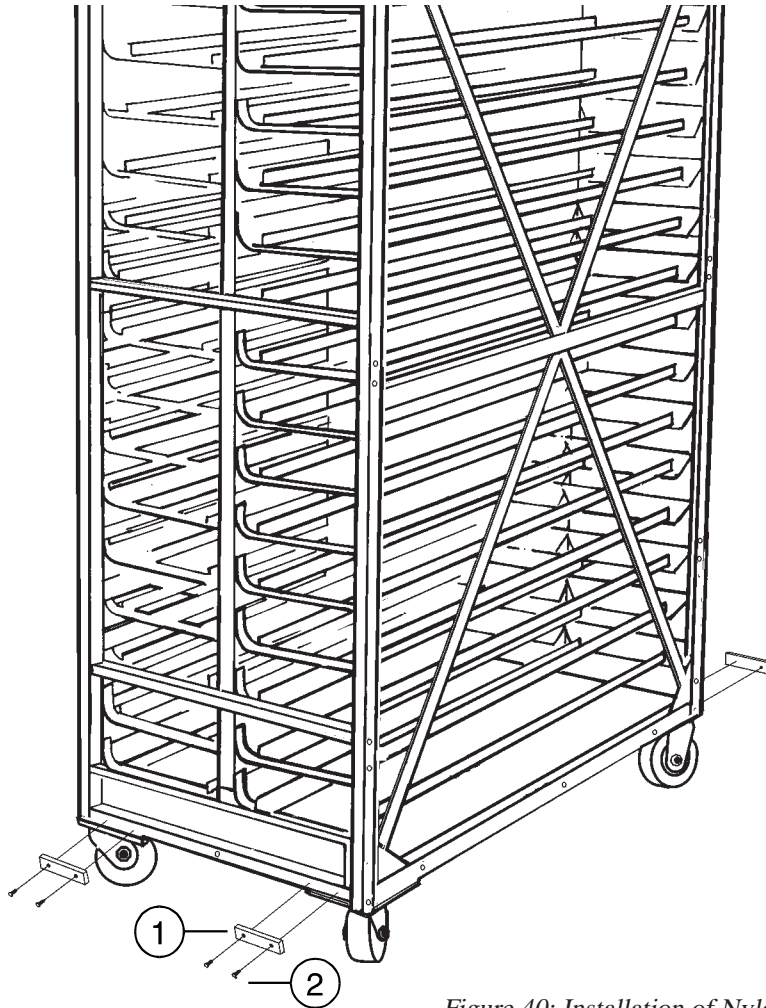

Figure 40: Installation of Nylon Bumpers

ITEM	PART No.	DESCRIPTION
1	PB5095	Nylon Bumper
2	P6200	Self Drilling/Tapping Screw

FINAL INSPECTION

Step 35: Stand the rack up on its casters (if necessary). Turn the columns of egg tray frames to the left and right, checking for smooth, easy turning. Ensure that the interconnect cables and air lines do not catch on any parts, or interfere with smooth turning of the rack. Correct any point of interference.

Step 36: Check the rack for squareness in all directions. Check all fasteners. Ensure the fasteners are not too tight.

Step 37: Add retaining rings (Item 1) to the rear frame rails of the two (2) centre hanging bars (Item 2). Counting from the top, they should be placed in the following positions:

Chicken Rack: 3 - 10 - 15

Turkey Rack: 3 - 9 - 14

The retaining rings should be placed on the inside as shown. See Figure 41. This procedure will eliminate any possibility of the egg tray frames falling from the pins.

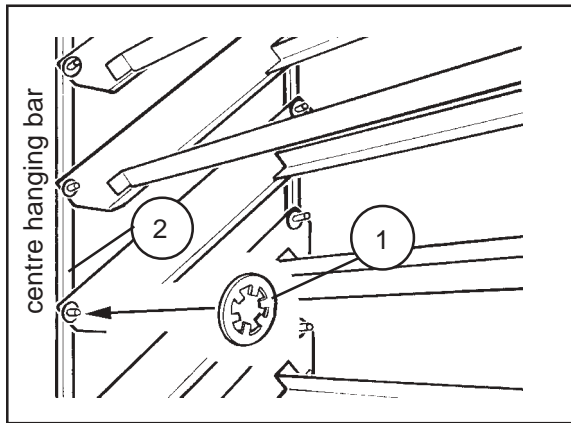

Figure 41: Adding Retaining Pins

ITEM	PART NO.	DESCRIPTION
1	PB3774	Retaining Ring
2	AB5696	Hanging Bar Assembly Chicken or,
	AB5848	Hanging Bar Assembly, Turkey

APPLICATION OF LOCKTITE

Step 38: When it is concluded that the rack is square and there are no points of interference with the egg trays; Loctite should be applied to the cap screws in these locations: between **both** side frame assemblies and the front rail spacers; between **both** side frame assemblies and the horizontal back rails; between **both** side frame assemblies and the bottom rail assemblies; and, between **both** side frame assemblies and the top frame assemblies (Figure 42).

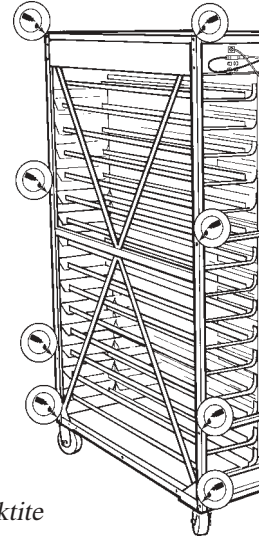

Figure 42: Application of Loctite

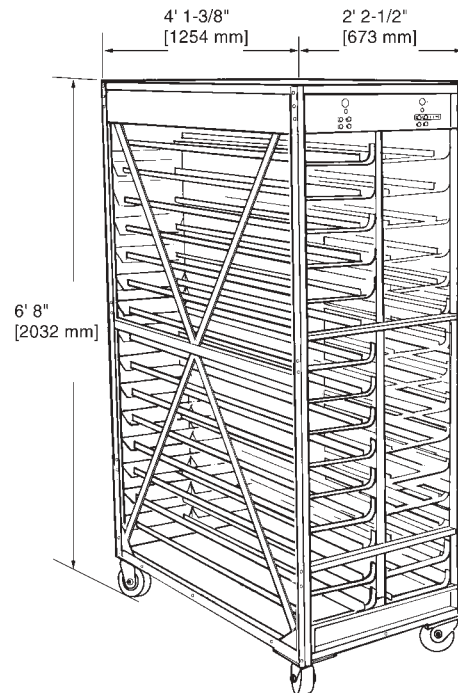

Figure 43: Dimensions of Completed Rack

ACCESSORIES AND REPLACEMENT PARTS

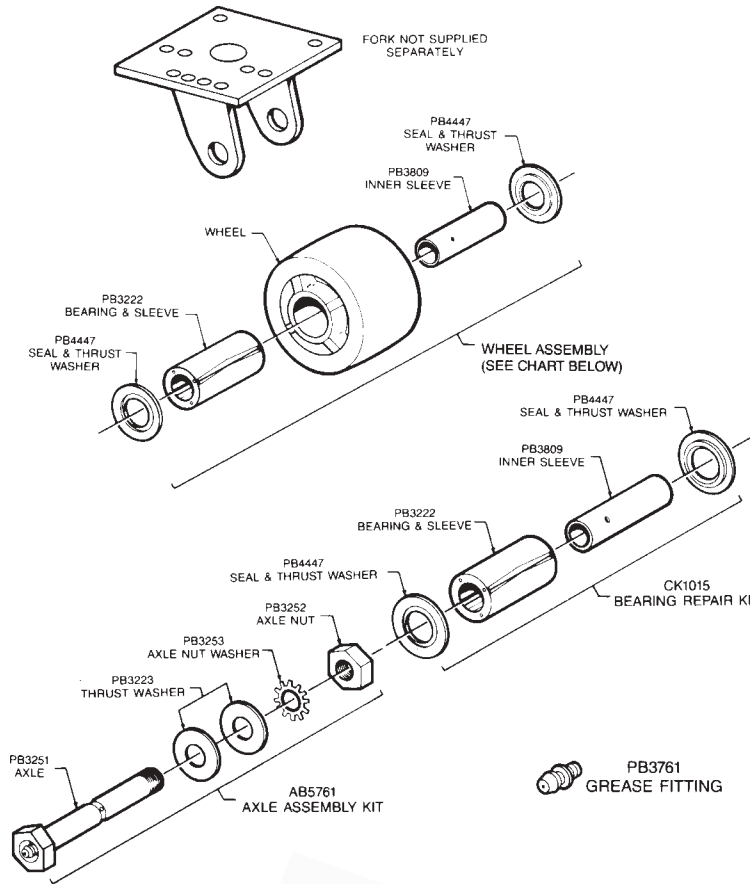

Figure 44: Replacement Parts for Casters
Polyolefin Swivel Caster (PB4355A)

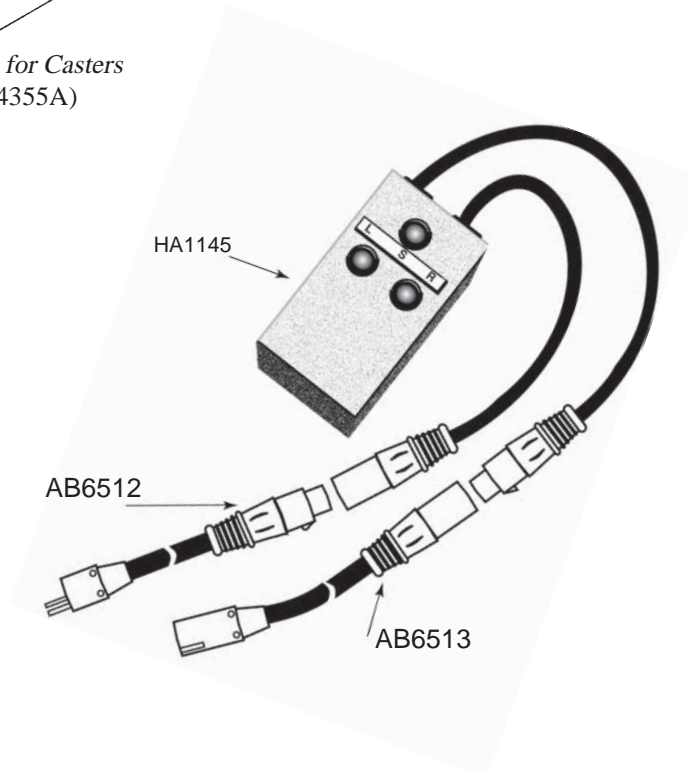

Figure 45: Incubator Rack Tester for 2-Column Racks
order HA1145 Inc. Rack Tester

A

AB3553	9
AB3556	16
AB3559P	18, 19
AB4101B	5, 13
AB5696	10, 12, 21
AB5848	10, 12, 21
AB5849	5, 13
AB6096	12
AB6144	12
AB6246	19
AB6247	19
AB6419	5
AB6420	13, 16
AB6421	6
AB6422	6
AB6424	5
AB6426	17
AB6512	22
AB6513	22
AB6537	19
AB6547	9

H

HA1145	22
--------------	----

M

MB16021	13
MB16292	19
MB16597	17
MB16705	11
MB16816	11
MB16856	11
MB16857	11
MB17090	19
MB17191	19
MB17260	16
MB17271	6, 9
MB17272	7
MB17280	10
MB17732	11
MB17733	11

O

O240528	6, 8, 9
O490500	6, 7, 8, 9
O660500	6, 8, 9
O880510	5, 6, 7, 9, 13

P

P2885	3
P2968	18
P3088	19
P3090	19
P3248	19
P336	17
P4253	18
P4254	18
P454	17, 18
P463	17, 19
P557	17, 19
P6060	16
P6067	11
P6082	18, 19
P6200	20
P814	19
P976	17, 18
PB12	17
PB1798	18
PB3294	19
PB3774	10, 12, 21
PB4355A	8, 9, 22
PB4389	19
PB4390	19
PB4665	3
PB4911	9
PB5075	19
PB5076	19
PB5086	18
PB5095	20

INSPECTION PROCEDURE

1. Review the assembly instructions before beginning rack assembly.
2. The assembler is to identify himself on the attached paper where noted and place the paper under the card clip on front bearing panel.
3. A Jamesway technician will inspect as per the attached procedure, mark the attached paper and then tick off that each individual test has been completed.
4. The assembler will finish the assembly and indicate on the paper that the assembly is completed.
5. The rack is then to be tested for air pressure and the test verified on the paper.
6. Leave the papers with the racks until all are completed.

Inspection Check List	1	2	3	4
Egg Tray Frames square to Frame and free floating (end play)	<input type="checkbox"/>	<input type="checkbox"/>	<input type="checkbox"/>	<input type="checkbox"/>
Retaining Rings in place on Hanging Bars	<input type="checkbox"/>	<input type="checkbox"/>	<input type="checkbox"/>	<input type="checkbox"/>
Retaining Rings in place on tier where specified	<input type="checkbox"/>	<input type="checkbox"/>	<input type="checkbox"/>	<input type="checkbox"/>
Front Rail Spacers at 90° to Rack Face	<input type="checkbox"/>	<input type="checkbox"/>	<input type="checkbox"/>	<input type="checkbox"/>
Wear Strips and Clips undamaged—front and back	<input type="checkbox"/>	<input type="checkbox"/>	<input type="checkbox"/>	<input type="checkbox"/>
Hanging Bars straight	<input type="checkbox"/>	<input type="checkbox"/>	<input type="checkbox"/>	<input type="checkbox"/>
Air Line Fittings on correct side of Air Cylinder	<input type="checkbox"/>	<input type="checkbox"/>	<input type="checkbox"/>	<input type="checkbox"/>
Both tiers turn without abnormal interference	<input type="checkbox"/>	<input type="checkbox"/>	<input type="checkbox"/>	<input type="checkbox"/>

Rack No. _____ Pre-assembled by _____ Inspected by _____ Final assembly by _____ Tested by _____ Ready for setting? _____	Rack No. _____ Pre-assembled by _____ Inspected by _____ Final assembly by _____ Tested by _____ Ready for setting? _____
Rack No. _____ Pre-assembled by _____ Inspected by _____ Final assembly by _____ Tested by _____ Ready for setting? _____	Rack No. _____ Pre-assembled by _____ Inspected by _____ Final assembly by _____ Tested by _____ Ready for setting? _____